

WH-PT Push Trolley

The William Hackett WH-PT Push Trolleys meet and exceed the requirements of international standard and British Standard BS EN 13157:2004 + A1:2009

This high quality trolley range is precision engineered in W.L.L. capacities from 500Kg to 10 tonnes.

Enabling exact positioning or easy traversing of large loads incorporating manual hoists, the William Hackett series push trolley can be supplied to suit various track widths within the standard beam range 1 and the extended beam range 2.

The runners (trolley wheels) are precision machined and they rotate on maintenance sealed ball bearings.

All William Hackett push trolleys are fitted with anti-jump bars and rubber end stops as standard.

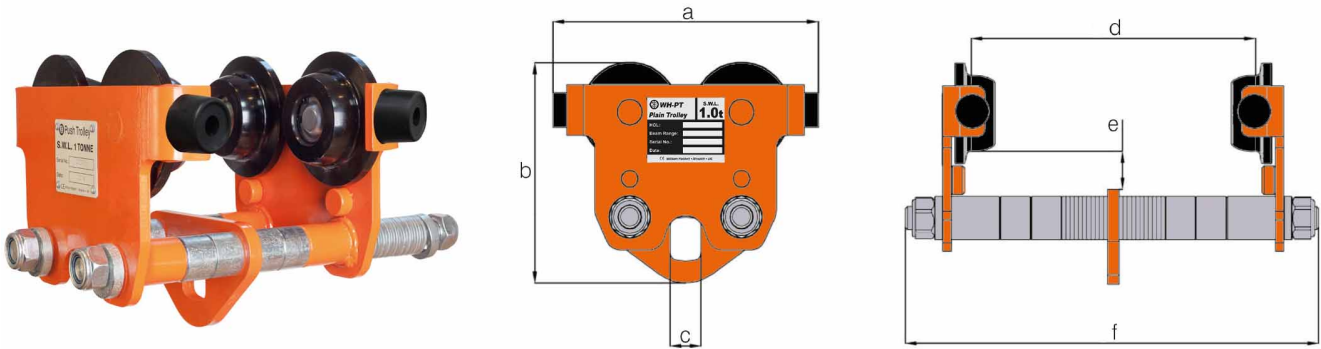

Specifications

Part Code	WLL t	Min.radius of Curve m	a mm	b mm	c mm	e mm	CAD Files
044.050	0.50	0.80	190	154	22	27	
044.100	1.00	0.90	206	180	30	26	
044.200	2.00	1.00	246	210	37	26	
044.320	3.20	1.20	300	249	42	28	
044.500	5.00	1.30	336	277	50	37	
044.1000	10.00	2.00	396	334	58	37	

Standard Range 1

WLL t	I Beam Width mm	d Max. width mm	f Max. mm	Mass kg
0.50	50-203	203	294	6.60
1.00	64-203	203	311	9.40
2.00	88-203	203	324	14.50
3.20	100-203	203	348	25.70
5.00	114-203	203	369	37.30
10.00	124-203	203	384	59.00

Extended Range 2

WLL t	I Beam Width mm	d Max. width mm	f Max. mm	Mass kg
0.50	-	-	-	-
1.00	64-305	305	413	11.10
2.00	88-305	305	426	16.30
3.20	100-305	305	450	28.50
5.00	114-305	305	471	41.00
10.00	124-305	305	486	64.00